

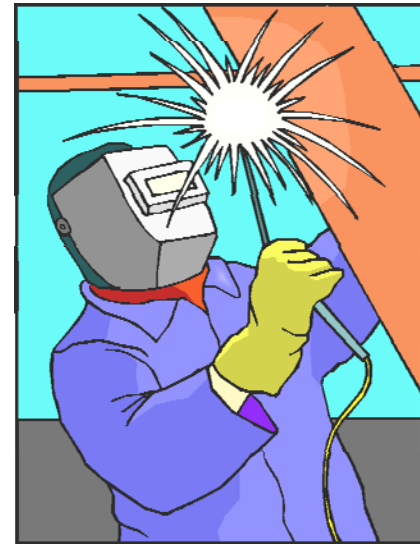

Welding Positions

Hosein Ali Tabibian (M.sc in Material Eng.)
M.sc_tabibian@yahoo.com



Test Position 1G (Flat)



Flat Plate ...

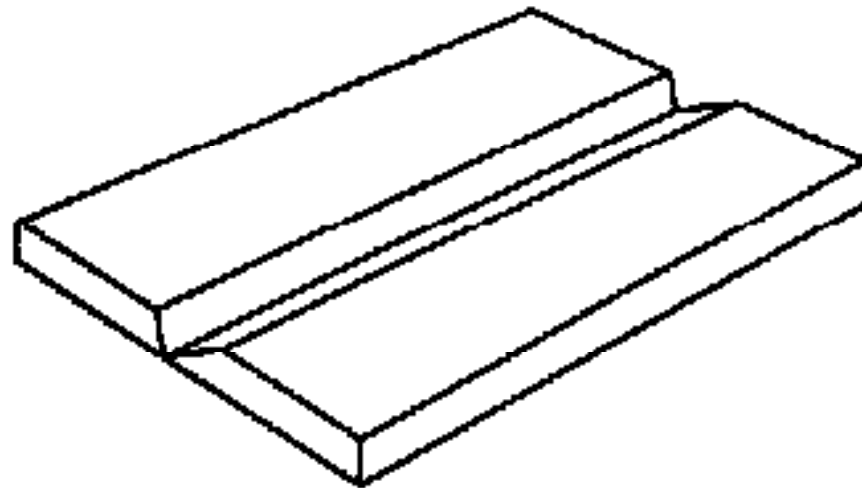

Test Position 2G (Horizontal)



Horizontal Plate ...

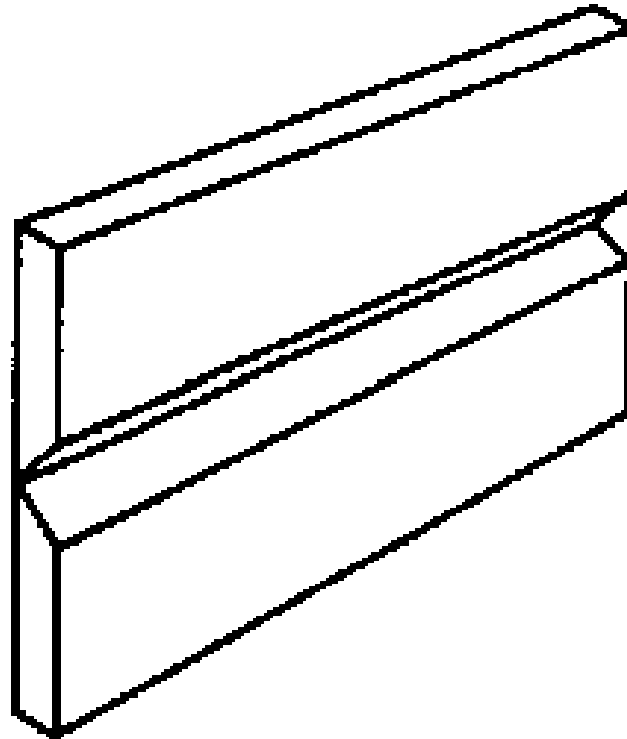

Test Position 3G (Vertical)



Vertical Plate ...



Test Position 4G (Overhead)



Overhead Plate ...

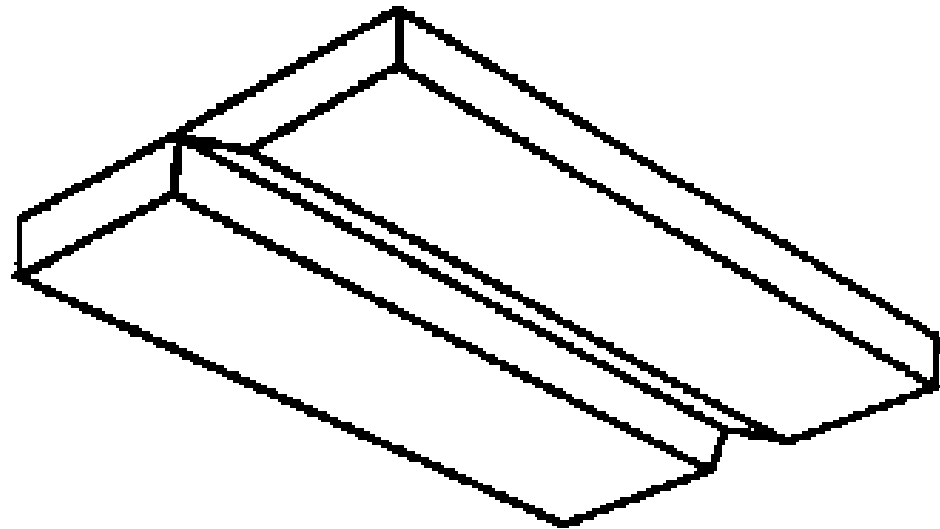



Test Position 1G (Rotated)

Pipe Horizontal and Rotated Weld Flat
Deposit Filler Metal At Or Near The Top...

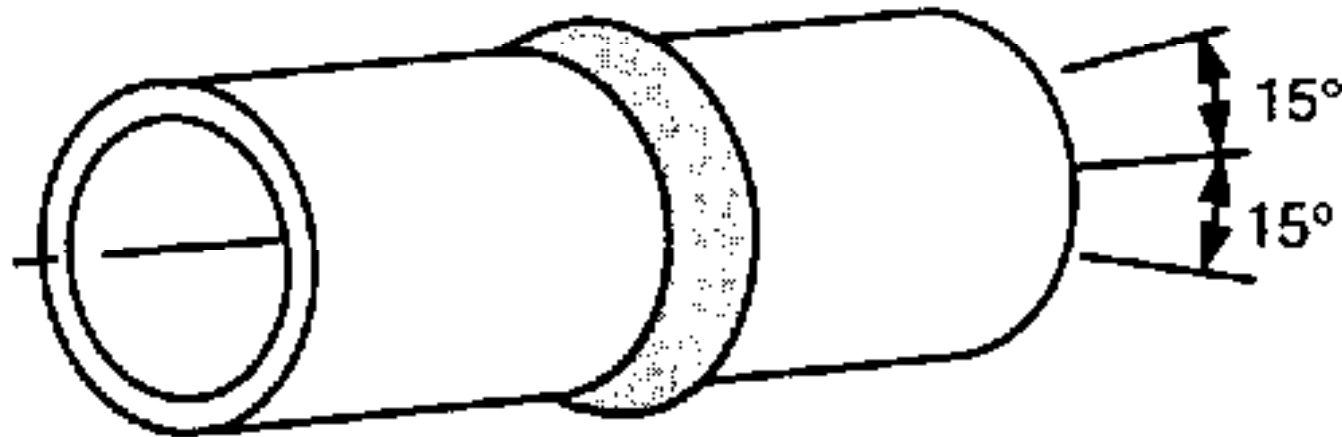

Test Position 5G



Pipe Horizontal Fixed And Not Rotated
During Welding ...
Qualifies Flat, Vertical, Overhead.

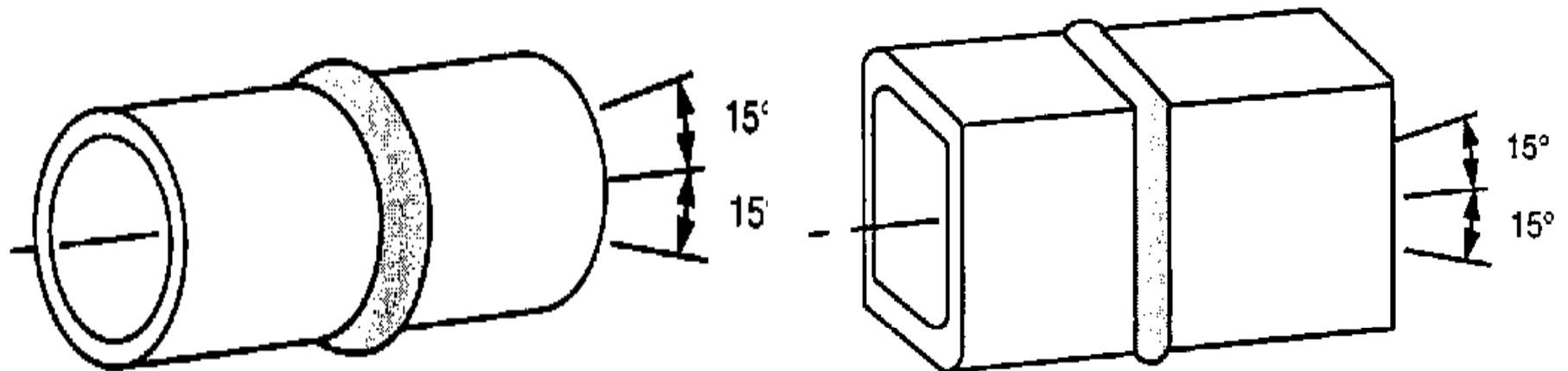

Test Position 6G



Pipe Inclination Fixed Angle And Not Rotated During Welding.

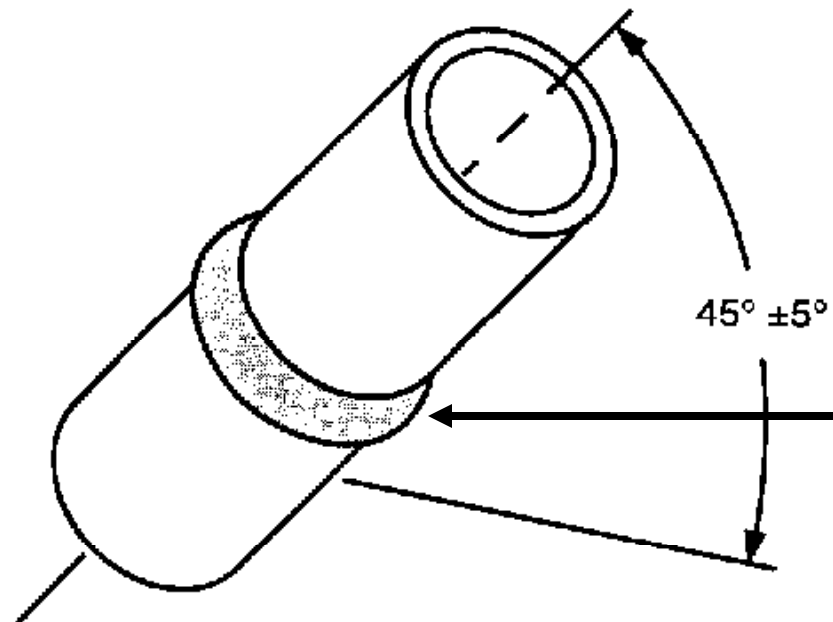

6G Qualifies
All Positions

Test Position 6GR



Test Position 6GR (T - Y - K - Connections).

Restricting Ring

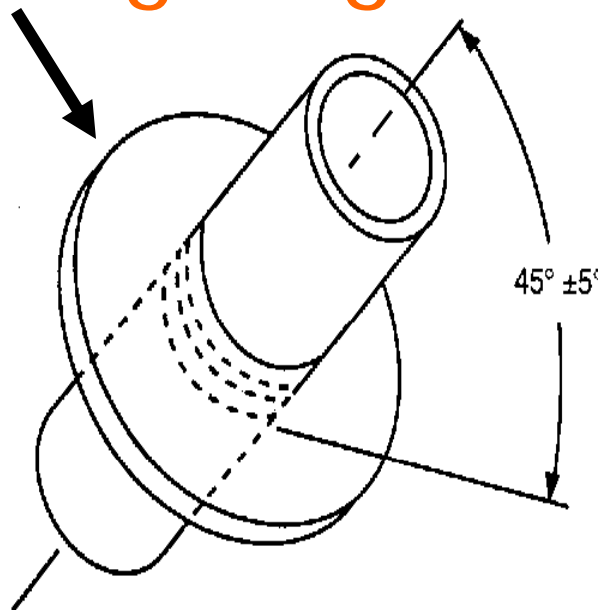

6GR
Qualifies All
Positions